

Rough Buck Frame Installation instructions

Table of contents

Introduction.....	Page 3
Receipt of merchandise.....	Page 4
General installation instructions.....	Page 4
Frame components.....	Page 5
Profile and dimensions.....	Page 6
Tools, hardware and parts.....	Page 7
Rough opening.....	Page 8
Wall construction and sub-frame applications.....	Page 9
Sub-frame installation.....	Page 11
Finished frame installation.....	Page 14
Submittals.....	Page 17
How to order.....	Page 17

The rough buck frame is a unique solution to replace an existing frame in a masonry wall. Fitting a square door in a non-square opening may result in unacceptable clearances between the door and the frame and may not provide workable hardware conditions for latching, gasketing or fire code requirements. Standard hollow metal frames do not allow for adjustment to compensate for out-of-square masonry openings and anchoring is unpredictable.

Rough buck frame benefits:

- ✧ Fire-rated up to 90 minutes; 8'0" x 8'0" maximum opening dimension.
- ✧ Flexibility on rough opening height: ¼" (6.4 mm).
- ✧ Flexibility on rough opening width: ½" (12.7 mm).
- ✧ The finish frame can be installed square, level and plumb.
- ✧ Solid anchorage of the frame; does not require grouting.
- ✧ Consistent clearance between the door and the frame provides compliance with codes and standards, energy efficiency, security and durability.

RECEIPT OF MERCHANDISE

- 1- Material must be handled and stored in compliance with NAAMM HMMA 840 (Guide Specifications for Installation and Storage of Hollow Metal Doors and Frames) or SDI 122 (Installation & Troubleshooting Guide for Standard Steel Doors and Frames). Refer to our website for a copy of these standards: www.delafontaine.com/installation
- 2- The installer must complete a thorough verification of products upon receipt or before installation.

INSTALLATION

The qualified installers must have a minimum of 3 years' experience in installing commercial steel doors, steel frames and hardware. The installer must have received factory training prior to installing the rough buck frame.

Before installing

1. Understand and follow the installation instructions of NAAMM HMMA 840 (Guide Specifications for Installation and Storage of Hollow Metal Doors and Frames), SDI ANSI A250.11 (Recommended Erection Instructions of Steel Frames) or SDI 122 (Installation & Troubleshooting Guide for Standard Steel Doors and Frames). The installation of fire-rated frames and doors must comply with NFPA 80 (Standard for Fire Doors and Other Opening Protectives). Refer to our website for a copy of these standards: www.delafontaine.com/installation
2. Inspect the product and make sure you have all the parts you need before you begin the installation.
3. Confirm product compliance with the approved door/frame/hardware schedule. Verify the door opening number, opening type, handing, width, height, and hardware prep (*is it the right product, in the right place?*). If this is not done, de La Fontaine will not assume any responsibility regarding installation problems.
4. If you encounter any problems, contact your supplier.
5. Make sure the frame is in good condition.

If you have any questions concerning the rough buck frame installation, please contact your representative for assistance.

ROUGH BUCK FRAME COMPONENTS

The rough buck frame is available in 16- or 14-gauge A40/A60 and stainless steel material or in 12-gauge A40 material.

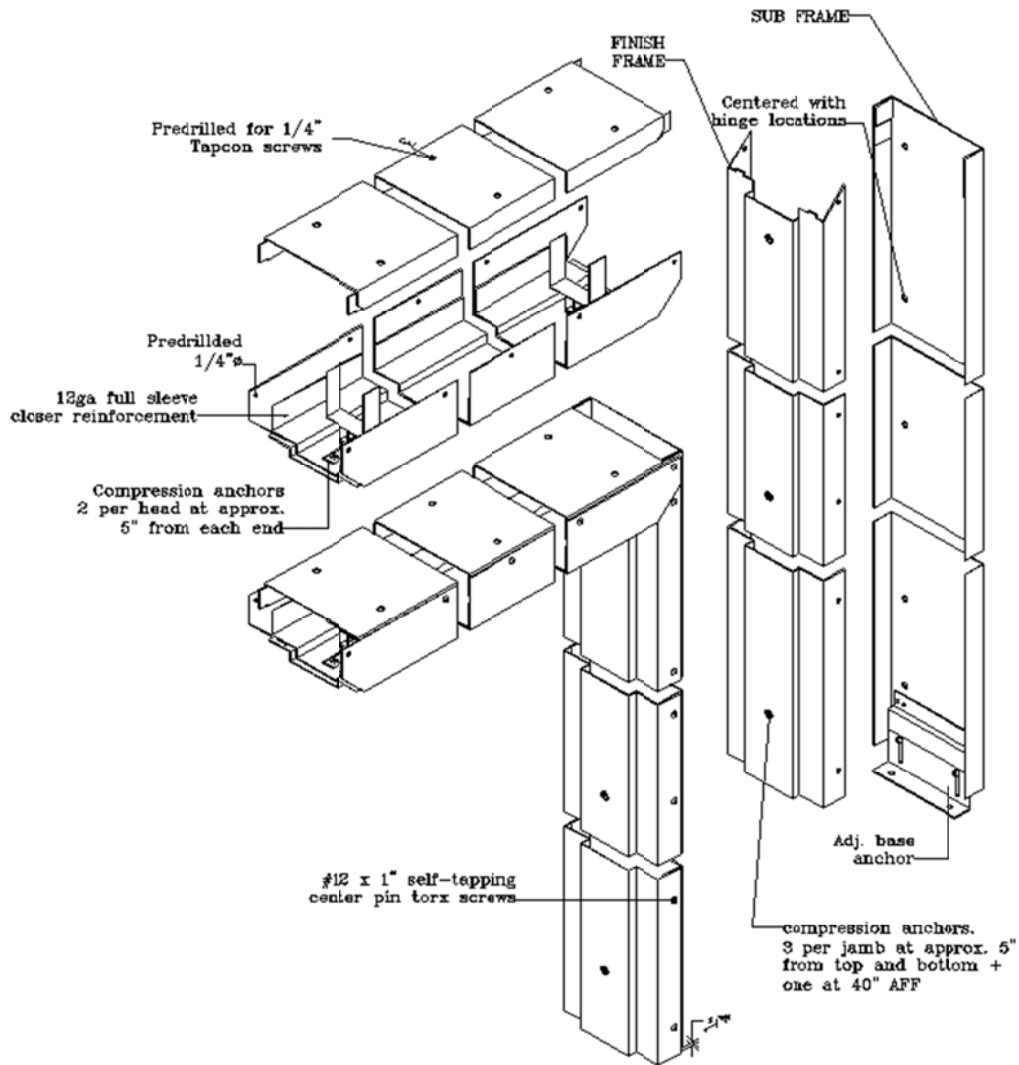

Image 1: Rough buck frame components

ROUGH BUCK FRAME PROFILE AND DIMENSIONS

The sub-frame face dimension is 1 1/2" (38.1 mm).

The face dimension of the finished frame is 1/4" (19.1 mm) smaller than the net face dimension. This is to compensate for variations in the masonry opening. The jamb face dimension is 2" (50.8 mm) and the head face dimension is 4" (101.6 mm). Please note these are the only face dimensions available.

The length dimension of the sub-frame/finished frame jambs is 1/4" (6.4 mm) shorter than the rough opening size to allow for adjustment and step over existing sill condition.

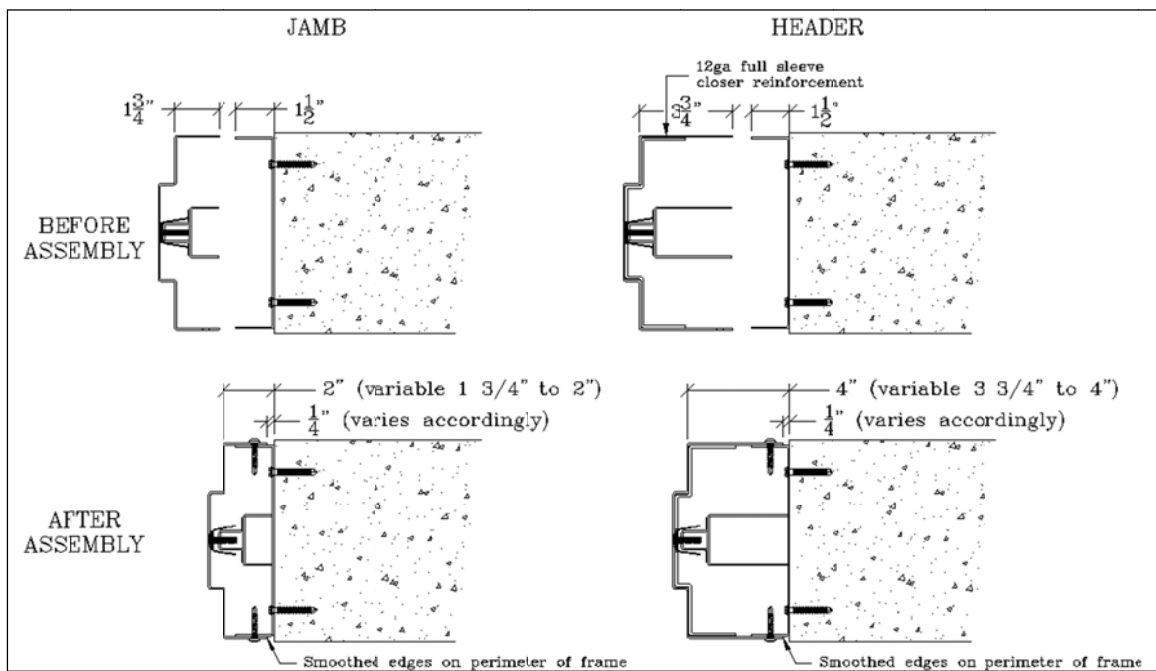







Image 2: Frame profile, section view

TOOLS, HARDWARE AND PARTS

1 - Tools for rough buck frame installation.

Drill		Measuring tape	
Level or Plumb Bob		Driver for Tapcon screw (Hex 5/16", 8 mm)	
Masonry bit (Ø 3/16", 4.8 mm)		Square	

2 - Parts for the rough buck frame installation, supplied by the manufacturer. If the wall condition does not allow the use of the following parts, installers must provide appropriate anchors.

PART #	DESCRIPTION
01	12-24 self-drilling torx center pin security screw (12-24 SDS)
02	Bit for torx security screw
03	1/4" (6.4 mm) Tapcon screw

3- Preparation included unless otherwise specified:

- a) Pre-drilled holes in sub-frame to receive 1/4" Tapcon screws;
- b) Pre-drilled holes in finish frame to receive 12-24 self drilling torx center pin security screw;
- c) Compression anchors;
- d) 14-gauge adjustable base anchor;
- e) 12-gauge full sleeve closer reinforcement;
- f) Mylard labels when fire labels are required;
- g) No prep for silencer holes.
- h) Butt or continuous hinge reinforcements per specification.

ROUGH OPENING

1- Preparation and dimensions

It is the contractor's responsibility to make sure the rough opening is suitable for the rough buck frame installation. The rough opening must be clean, free of debris, plumb and must offer a solid surface to screw the sub frame in.

The nominal door opening size is 4" (101.6 mm) smaller than the rough opening width and 4" (101.6 mm) smaller than the rough opening height.

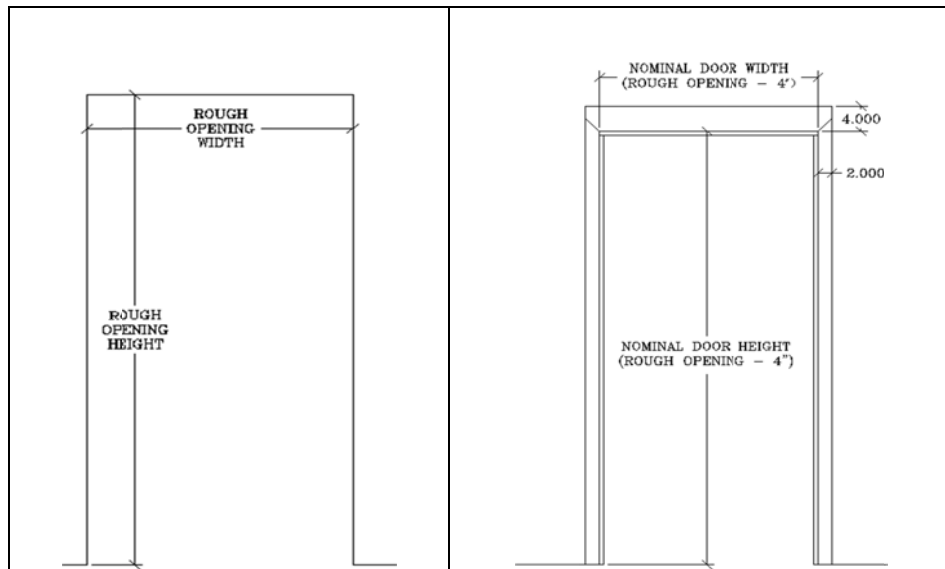

Image 3: Calculation of the nominal door opening size

2- Wall construction and sub-frame application

It is the contractor's responsibility to provide the most accurate information possible on existing wall conditions and to make sure the rough buck frame can be installed properly. According to our experience, two types of wall construction are more common.

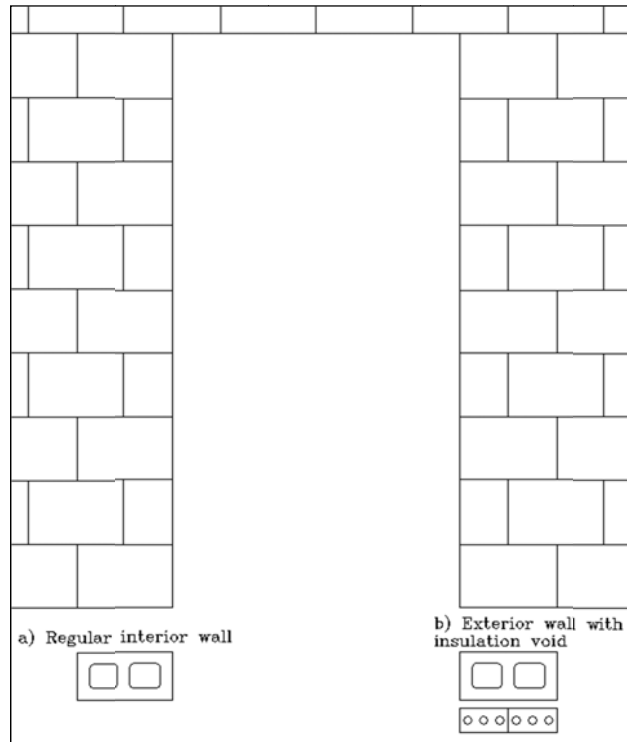

Image 4: Interior block wall and exterior block wall with cavity and brick

Usually, the installation of the sub-frame in the standard interior block wall is easy since a full solid surface is available to anchor the sub-frame.

However, the installation of the sub-frame in a cavity wall (see image 4b) can be compromised by a limited solid surface to screw into and it may require a larger sub-frame dimension. It is the contractor's responsibility to evaluate the condition and **provide a minimum of 4" (101.6 mm) of solid surface** on one side to butt the sub-frame (the sub frame should overlap the block as much as possible) and a solid surface to support the opposite side of the jamb depth (brick in this example).

The sub-frame jamb depth will depend on the wall dimensions; however, if the section overlapping insulation components (soft surface) is 4" (101.6 mm) or more (see dimension "a" on image 5), the sub-frame must receive additional reinforcement (see image 6). Please advise the factory.

Note: if the jamb depth is 5 3/4" (146 mm) or more, the sub-frame will automatically receive the reinforcement.

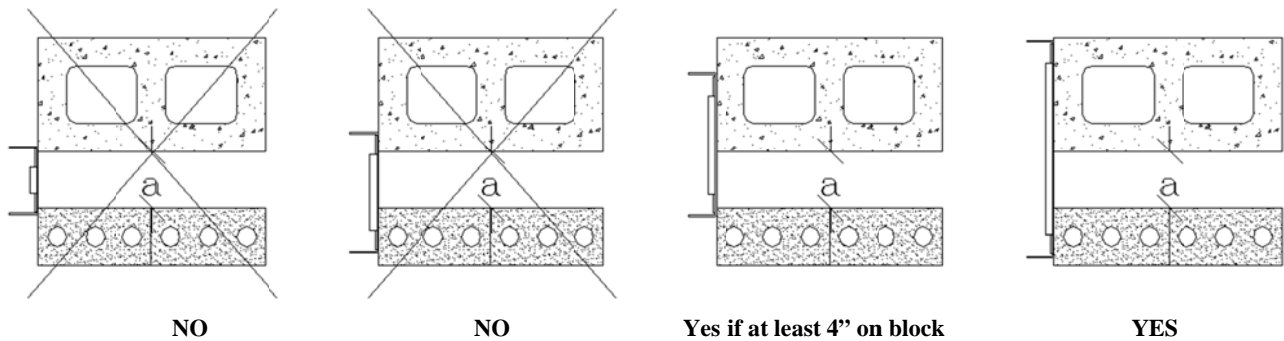

Image 5: Sub-frame installation in an insulated wall

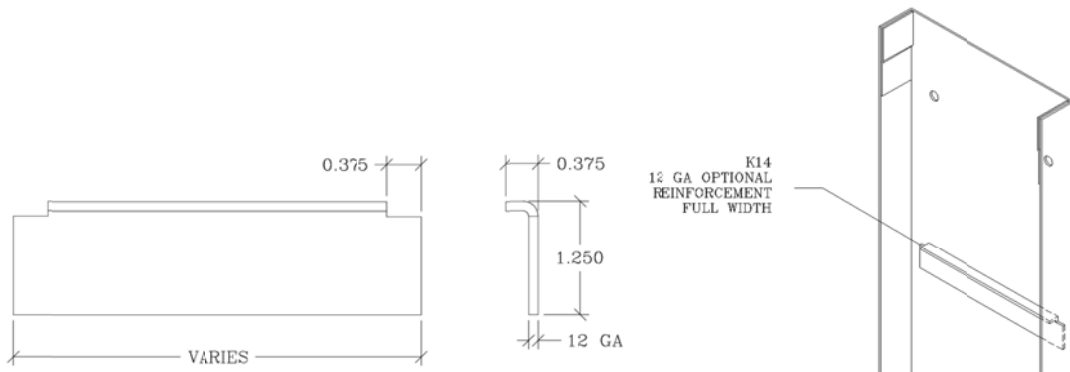

Image 6: Detail of sub-frame optional reinforcement

ROUGH BUCK FRAME INSTALLATION

- 1- Unpack the frame.
- 2- Place the finished frame in a secure area.
- 3- Sub-frame installation
 - a) Angle one jamb against one side of the rough opening (note: jambs' lengths are 1/4" (6.4 mm) less than the rough opening to allow for adjustment).

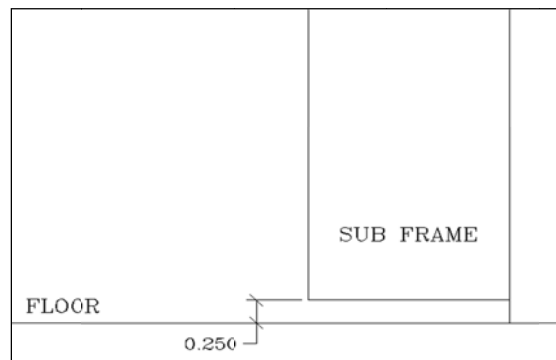

Image 7: 1/4 inch adjustment at the bottom of jamb

- b) Attach the header by aligning the tabs into the slots of the jamb. Angle and insert the second jamb into the header. The sub-frame head must fit tight to the TOP of the rough opening. Sub-frame jambs must fit tight to TOP CORNER and SIDE of the rough opening (leaving approximately 1/4" (6.4 mm) gap at bottom of sub-frame to floor.

Where the sub-frame head and sub-frame jamb intersect, it is possible to have a slight gap. This could be due to:

- 1) The rough opening being slightly wider than intended;
- 2) The rough opening tops having slightly tapered cuts;
- 3) The rough opening sides having slightly tapered cuts.

Please note that this is acceptable and not a concern.

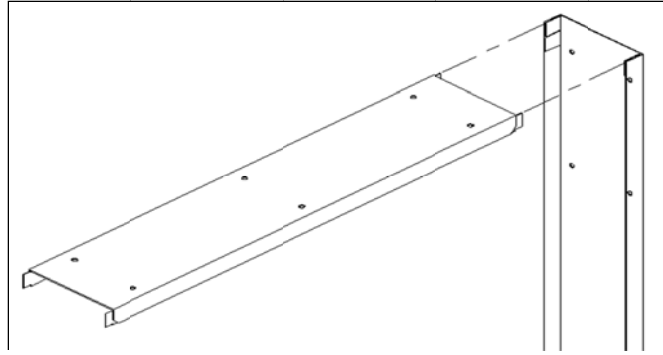

Image 8: Head tabs into jamb slots

- c) Make sure the jamb are tight at the top corners (as previously mentioned, leaving approximately ¼” (6.4 mm) gap at the bottom) and attach to the masonry opening with one Tapcon screw at the top of each jamb to allow for movement of the bottom of the jamb during alignment (could vary by ¼” (6.4 mm) depending on exact rough opening height; this is acceptable).

If pre-drilled holes do not hit solid substrate, re-drill to solid area.

- d) The sub-frame does not have to be square, but the sub-frame jambs must be parallel to each other (see image 9). The faces of the sub-frame must be plumb and aligned. This step is **extremely critical** for the proper installation of the frame.

Ensure parallel placement of the jambs within the specified tolerance of 1/16” (1.6 mm).

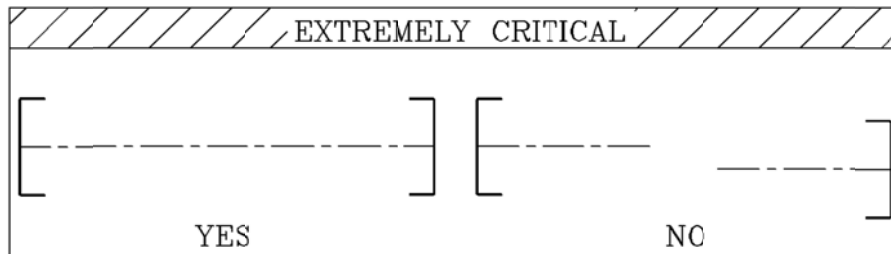

Image 9: Alignment of frame jambs

- e) Shim as necessary behind the sub-frame to avoid twisting of the frame (fire-rated openings must have metal shims) (see image 10).

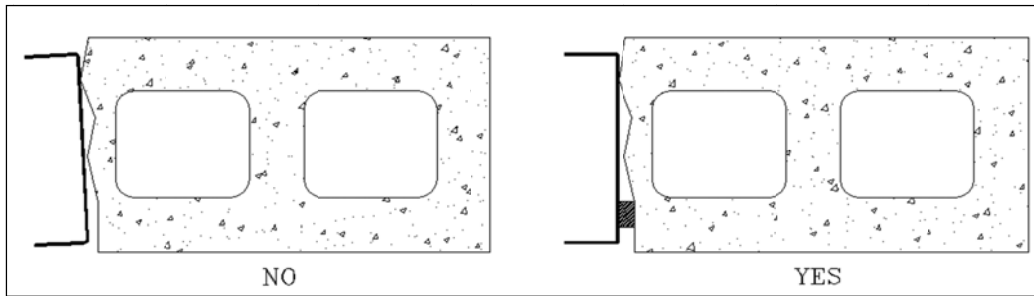

Image 10: Set the jambs to avoid twisting

- f) Adjust the adjustable floor anchors and attach to the floor (see image 11).

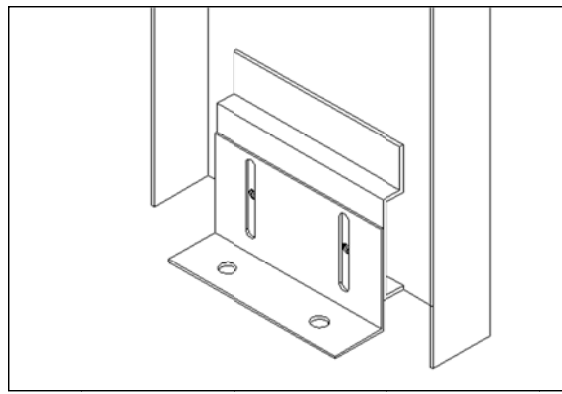

Image 11: Adjustable floor anchor set to floor position

- g) Adjust the jamb legs as required and install the remaining Tapcon screws in pairs and secure the sub-frame to rough opening. Screw Tapcon screws at the top, at hinge location and at the bottom of the sub-frame. Make sure to screw into concrete and not into mortar. If pre-drilled holes are located at mortar height, drill a new set of holes to be located at concrete height.

3) Finished frame installation

- a) Install the finished frame hinge jamb, for correct swing of the door, to completely overlap the sub-frame, set the header by aligning the tabs of the jamb into the slots of the header and repeat with the strike jamb (see image 12).

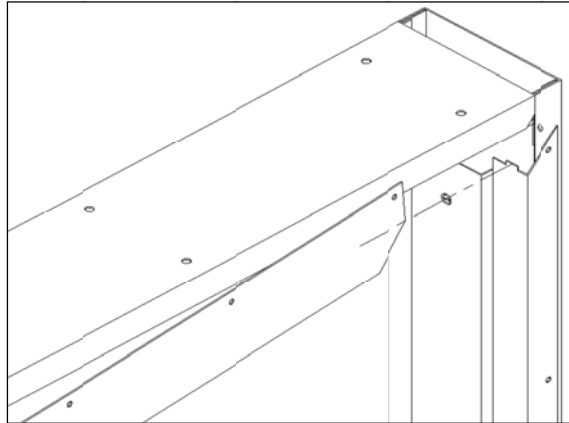

Image 12: Align tabs of jamb in slots of header

- b) Use a spreader bar to obtain exact dimensions of the finished opening and insert between the jambs at the floor to ensure proper sizing of the finished opening (see image 13).

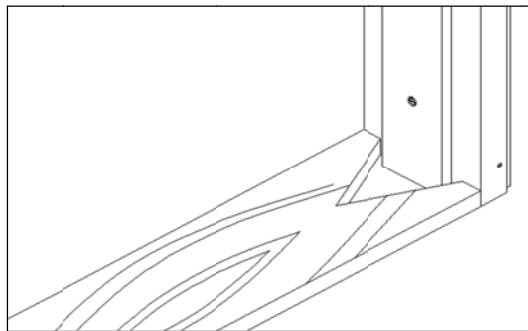

Image 13: Use of the spreader bar

- c) Adjust the compression anchors at the top of jamb and header to draw the miter joint tightly together. Check for square alignment between head and side jambs.

- d) Adjust the bottom compression anchor to the width of the spreader bar and verify that the header remains square.
- e) Install 12-24 self-drilling center pin torx security screws at the joint of the head and side jamb and at the bottom of the hinge jamb (see image 14). Use of a center punch is strongly recommended to start holes, to ensure proper alignment.

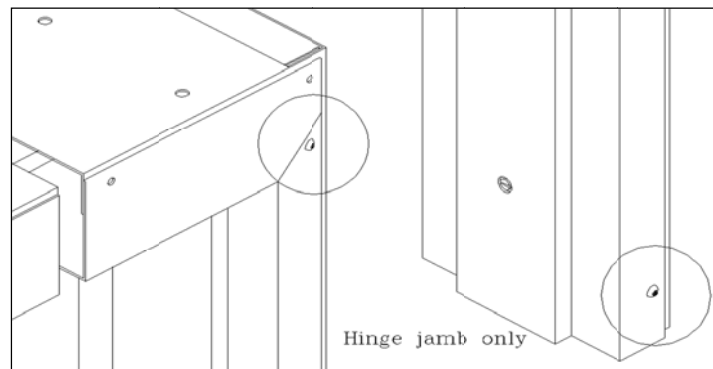

Image 14: Screw top and bottom torx security screw on hinge jamb

For single opening

- f) Verify that the hinge jamb is set square, plumb and parallel. Install center pin torx security screws in all remaining hinge jamb holes. Use of a center punch is strongly recommended to start holes, to ensure proper alignment.
- g) Install the door, to be used as a template to complete proper installation of the strike jamb.
- h) Verify that the clearance between the top of door and the header is 1/8" (3.2 mm) +/- 1/16" (1.6 mm).
- i) Adjust the strike jamb to be square, plumb and parallel. Verify that the clearance between the door edge and the frame rabbet is 1/8" (3.2 mm) +/- 1/16" (1.6 mm).
- j) Install center pin torx screws in all remaining holes on the strike jamb. It is imperative that screws are centered. Use of a center punch is strongly recommended to start holes, to ensure proper alignment.
- k) Provide sealant to eliminate any gaps between the frame face and the masonry.

For double opening

- f) Verify that the hinge jamb is set square, plumb and parallel. Drill, tap and install center pin torx security screws in all remaining hinge jamb holes.
- g) On the second hinge jamb, adjust the compression anchors at the top of the jamb and the header to draw the miter joint tightly together. Check for square alignment between the head and side jambs.
- h) Adjust the bottom compression anchor to the width of the spreader bar and verify that the header remains square.
- i) Install 12-24 self-drilling center pin torx security screws at the joint of the head and side jamb and at the bottom of the hinge jamb (see image 14). It is imperative that screws are centered. Use of a center punch is strongly recommended to start holes, to ensure proper alignment.
- j) Verify that the second hinge jamb is set square, plumb and parallel. Drill, tap and install center pin torx security screws in all remaining hinge jamb holes. It is imperative that screws are centered. Use of a center punch is strongly recommended to start holes, to ensure proper alignment.
- k) Provide sealant to eliminate any gaps between the frame face and the masonry.

SUBMITTALS

We have created specific submittal sheets for the rough buck frame. Please use them for your projects. The following submittal sheets are useful and they are available on our website in the distributor's corner:

- 1) General notes SS-02
- 2) RBF and Door Schedule SS-10
- 3) RBF details SS-09
- 4) Frame irregular position SS-29A
- 5) Door irregular position SS-30A and SS-30B

HOW TO ORDER THE ROUGH BUCK FRAME

- 1) Make sure the rough opening is suitable for a rough buck frame application. The sub-frame must butt a minimum of 4" (101.6 mm) over a solid surface to drill in. A solid surface to support the opposite side of the jamb depth must also be available. Please review page 9, 'Wall construction and sub-frame application', of this document.
- 2) Sub-frames installed in a cavity wall (see images 4 and 5 of this document) must have reinforcement if the section overlapping insulation components or a void (soft surface) is 4" (101.6 mm) or more. The factory will add the reinforcement automatically for jamb depths of 5 3/4" (146 mm) or more.
- 3) The distributor is responsible for the nominal dimension calculation. The rough buck frame is only available in 2" (50.8 mm) face jambs and 4" (101.6 mm) face head. Please review image 3 of this document on how to calculate the nominal opening size. To avoid confusion, do not provide other dimensions on the order form.
- 4) Complete the order form, select type J8 Rough Buck Frame and include nominal opening size ONLY.

LINE #	FRAME QUANTITY	TYPES	IF BORROWED OR SIDELIGHT REFERENCE A DRAWING	DOOR OPENING SIZES	HANDING	STEEL	FIRE LABEL CODE	"X" IF FINISHED LABEL (BTZ)	PROFIL	RETURN	GAGE	JAMB DEPTH	OTHER FACE HEAD	ASSEMBLY	ANCHORS	ADDITIONAL ANCHORS	HINGES	ADDITIONAL OPTION ON HINGE	QTY	HARDWARE LOCATION	HEAD PREP.	STRIKES	ADDITIONAL STRIKES
				Width	Height																		
				FEET	INCHES	FEET	INCHES																
1																							
				TYPES Leave blank if standard #3 Dutch door frame #4 Communicating frame #5 Case Opening frame #6 Transom frame without bar #7 Split frame (DR series only) #8 Rough buck frame																			
2																							
3																							

Image 16: Example of rough buck frame order sheet being filled out

If you have any questions regarding the rough buck frame, please do not hesitate to communicate with your sales representative.